



## Microbial Biotechnology

**T**he Department of Molecular Microbiology integrates research aimed at gaining knowledge on key aspects of microbial biology with environmental, clinical or biotechnological relevance. Work, organised in twelve distinct lines, exploits several complementary aspects of microbial biology, with approaches that include molecular genetics, genomics, proteomics and metagenomics. The subjects studied include:

- Environmental microbiology. We aim to understand how microorganisms degrade organic compounds that generate environmental problems, as well as why a microorganism that can efficiently degrade a compound of interest under laboratory conditions does usually not perform so well under natural conditions.
- Microbial responses to hostile environments. The focus is to understand bacterial responses to stressful environments, including the reaction to host defence responses and to agents causing DNA damage. We study how opportunistic pathogens adapt to survive within a host, eliciting defence responses against the immune system, and how bacteria and fungi replicate DNA and repair DNA damages to improve genome stability.
- Microbial pathogens. Efforts are directed to understand how microbial pathogens infect or invade a eukaryotic host, with particular emphasis on the host-pathogen interactions occurring in infections caused by intracellular bacterial pathogens and phytopathogenic fungi. This will facilitate finding new targets to combat microbial diseases relevant in human health and agriculture.
- Microbial resistance to antibiotics and search for new antimicrobials. We aim to understand mechanisms of bacterial resistance to antibiotics and to analyse the complex responses elicited upon exposure of microbes to sublethal concentrations of antibiotics. In addition, we search for new antimicrobials and new potential targets in essential functions to fight against pathogens.
- Microbial engineering. The purpose is to generate bacterial strains optimised to obtain products of interest (recombinant antibodies, hydrolytic enzymes or antimicrobial compounds), or to detect and degrade pollutants. Efforts are also made towards understanding the mechanisms used by bacteria to export and secrete proteins.

These topics are highly interconnected. While most established pathogens normally cope with stressful conditions by developing efficient adaptive responses, the opportunistic pathogens are metabolically very versatile, what makes them efficient biodegraders of organic chemicals. Fighting against pathogenic microorganisms requires a deep understanding of their behaviour during infection and of how resistance develops as pathogens are challenged by antibiotics.



JUAN C. ALONSO Genetic Stability	78
SILVIA AYORA HIRSCH Recombination-Dependent DNA Replication	80
JESÚS BLÁZQUEZ Stress and Bacterial Evolution	82
ARTURO CALZADA Cell Cycle, DNA Replication and Genome Stability in Eukaryotes	84
LUIS ÁNGEL FERNÁNDEZ HERRERO Protein Secretion and Antibody Expression	86
FRANCISCO GARCÍA-DEL PORTILLO Intracellular Bacterial Pathogens	88
FRANCISCO MALPARTIDA ROMERO Molecular Genetics of Streptomyces	90
JOSÉ PÉREZ MARTÍN Molecular Mechanisms of Fungal Virulence	92
JOSÉ LUIS MARTÍNEZ Opportunistic Pathogens	94
RAFAEL P. MELLADO Heterologous Gene Expression and Secretion in Gram-positive Bacteria of Industrial Application	96
FERNANDO ROJO Regulation of the Metabolism of Hydrocarbons in Bacteria	98
MIGUEL VICENTE Genetic Control of the Cell Cycle	100

## Microbial Biotechnology

LEAD INVESTIGATOR

Juan C. Alonso

POSTDOCTORAL SCIENTISTS

Candela Manfredi  
Carolina Elvira  
Cristina Machón  
Nora E. Soberon



PREDOCTORAL SCIENTISTS

Paula Cardenas  
Cristina Cañas  
Inmaculada Dalmau  
Virginia Lioy  
Tribhuwan Yadav

TECHNICIAN

Chiara Marchisone

## Genetic Stability

Our aim is to characterise the involvement of DNA repair and segregation in the stability of the genetic material in Firmicutes using two model systems.

*Bacillus subtilis* is used to study repair-by-recombination, and plasmid pSM19035 to study segregational stability. In the first model, we showed that i) during double-strand break repair, RecN in concert with polynucleotide phosphorylase (PNPase) promotes the dynamic recruitment of DNA ends. PNPase distributively removes few nucleotides from the 3'-end, ii) AddAB or RecJ, in concert with a RecQ-like helicase (RecQ or RecS), creates 3'-ssDNA tails at the break, and RecN recruits recombination proteins to form a repair centre, iii) various mediators (e.g., RecO, RecU) modulate the activity of the recombinase RecA, iv) the RecO mediator mediates second end capture (Fig. 1), and v) the branch migration helicases (RecG and RuvAB), and the resolvase (RecU) process recombination intermediates.

In the second model system, we showed that i) the role of pSM19035 global regulator  $\omega$  protein (a dimer in solution,  $\omega_2$ ) is to control the fine-tuning of plasmid copy-number, plasmid segregation, and  $\epsilon$  and  $\zeta$  expression. In addition, ii) the partitioning protein  $\omega_2$  binds to a centromeric-like region, forming a left-handed protein matrix surrounding the straight parS DNA (partition complex, PC), and protein  $\delta$  (a dimer in solution,  $\delta_2$ ) hydrolyses ATP preferentially in the presence of  $\omega_2$  bound to parS (segrosome complex, SC) or non-parS DNA (dynamic complex, DC) and binds DNA after interacting with  $\omega_2$ , promoting plasmid pairing (bridging complex, BC) at parS DNA or pseudo bridging complex ("BC") at non-parS DNA. Finally, iii) the  $\delta_2$  disassembly from DNA is dependent on the stoichiometry of the  $\omega_2:\delta_2$  complex.

The different stages are summarized in Fig. 2.

Scientific Report 09-10  
Centro Nacional de Biotecnología CNB

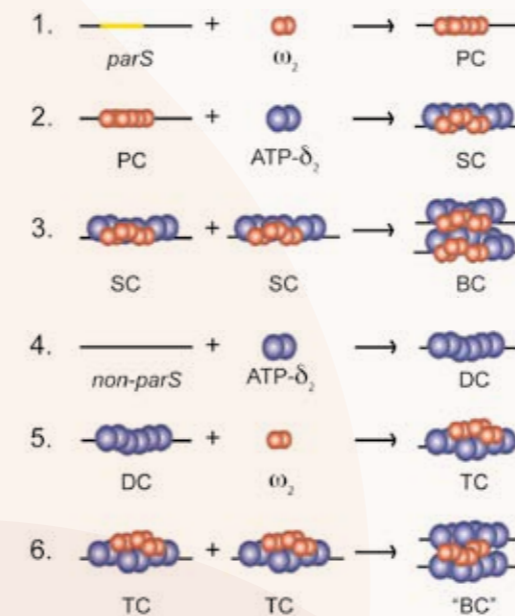

Fig. 2. Dynamic assembly of different types of protein-DNA complexes. Protein  $\omega_2$  bound to parS DNA led to the formation of a partition complex (PC, 1);  $\delta_2$  bound to PC led to segrosome complex (SC, 2) formation, and the interaction of two SC led to bridging complex (BC, 3) formation. Protein  $\delta_2$  bound to any DNA (non-parS DNA) led to dynamic complex (DC, 4) formation;  $\omega_2$  binding to DC led to a transient complex (TC, 5), and the interaction of two TCs led to pseudo-bridging complex ("BC", 6) formation.

## SELECTED PUBLICATIONS

Carrasco B, Cañas C, Sharples GJ, Alonso JC, Ayora S (2009) The N-terminal region of the Firmicutes RecU Holliday junction resolvases is essential for homologous recombination. *J Mol Biol* 390:1-9.

Smit C, Chechik M, Kovalevskiy OV, Shevtsov MB, Foster WA, Alonso JC, Antson AA (2009) Nuclease domain from a bacteriophage large terminase has an RNase H-like fold with an occluded active site suggesting a mechanism of regulation. *EMBO Rep* 10:592-598.

Cardenas P, Carrasco B, Sanchez H, Deikus G, Bechhofer D, Alonso JC (2009) *Bacillus subtilis* polynucleotide phosphorylase 3'-to-5' DNase activity is involved in DNA repair. *Nucl Acids Res* 37:4157-4169.

Pratto F, Suzuki S, Takeyasu K, Alonso JC (2009) Single-molecule analysis of protein-DNA complexes formed during partition of newly replicated plasmid molecules in *Streptococcus pyogenes*. *J Biol Chem* 284:30298-30306.

Kidane D, Carrasco B, Manfredi C, Rothmaier K, Ayora S, Tadesse S, Alonso JC, Graumann PL (2009) Evidence for different pathways during horizontal gene transfer in competent *Bacillus subtilis* cells. *PLoS Genetics* 5: e1000630.

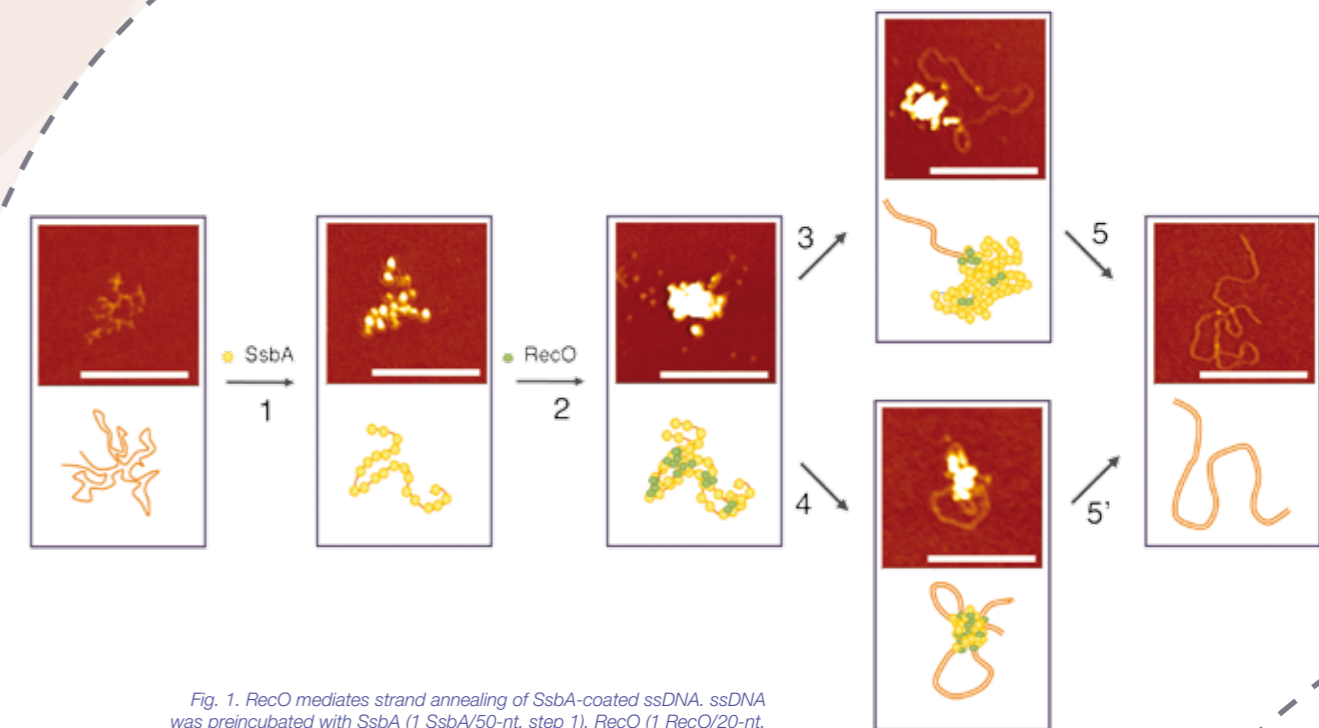

Fig. 1. RecO mediates strand annealing of SsbA-coated ssDNA. ssDNA was preincubated with SsbA (1 SsbA/50-nt, step 1). RecO (1 RecO/20-nt, step 2) was added and the reaction incubated for a variable time (steps 3 to 5'). In steps 3 and 4, a partial RecO-mediated dislodging of SsbA leads to RecO-promoted homology search and strand annealing. In steps 5 and 5', RecO-mediated strand annealing leads to the naked dsDNA product. Samples were taken at different times. Schematic representation of the images is shown below. Scale bar = 200 nm.

## Microbial Biotechnology

LEAD INVESTIGATOR

Silvia Ayora Hirsch

PREDOCTORAL SCIENTISTS

Ambra Lo Piano  
Andrea Volante  
Esther García Tirado



TECHNICIAN

María López Sanz

## Recombination-Dependent DNA Replication

A central problem in biology is the faithful transmission of hereditary information from mother to daughter cells.

This process not only involves precise replication of chromosomal DNA, but also correct partitioning of the newly synthesized sister chromosomes. It has become clear over the last decade that the progression of replication forks in living cells and their viruses is disrupted with high frequency, by encountering various obstacles either on or in the DNA template. Survival of the organism then becomes dependent both on removal of the obstacle and on restart of DNA replication. Homologous recombination is a process that takes place in all living cells to generate diversity, DNA repair, and for correct segregation of the chromosomes. It is also necessary to properly reassemble the arrested replication fork (Fig. 1). The study of homologous recombination mechanisms has revealed the complexity of the recombination process, due to the large number of proteins involved. Simple model systems such as bacteria and their viruses (bacteriophages) are therefore good candidates for deciphering these complex mechanisms.

We are analyzing how a replication fork is reassembled, and how replication can restart by a recombination-dependent mechanism, using *Bacillus subtilis* and its bacteriophage SPP1. In these two models, the outcome of the recombination-dependent replication is different, as in the bacteria the product is replication restart by a theta mechanism, whereas in SPP1, replication restart leads to concatemeric DNA synthesis which is the substrate for viral DNA packaging. The latter type of replication is also found in herpes simplex virus, baculovirus, mitochondrial DNA, chloroplast DNA, telomeric circles, and certain pathogenicity islands, and takes place by a poorly characterized mechanism.

In the *B. subtilis* work, we focus mainly on the RecU Holliday junction (HJ) resolvase and the RecU modulators RuvA and RuvB (Fig. 2). This enzyme has three activities: (i) it cleaves HJ, (ii) anneals complementary strands and (iii) modulates RecA

Scientific Report 09-10  
Centro Nacional de Biotecnología CNB

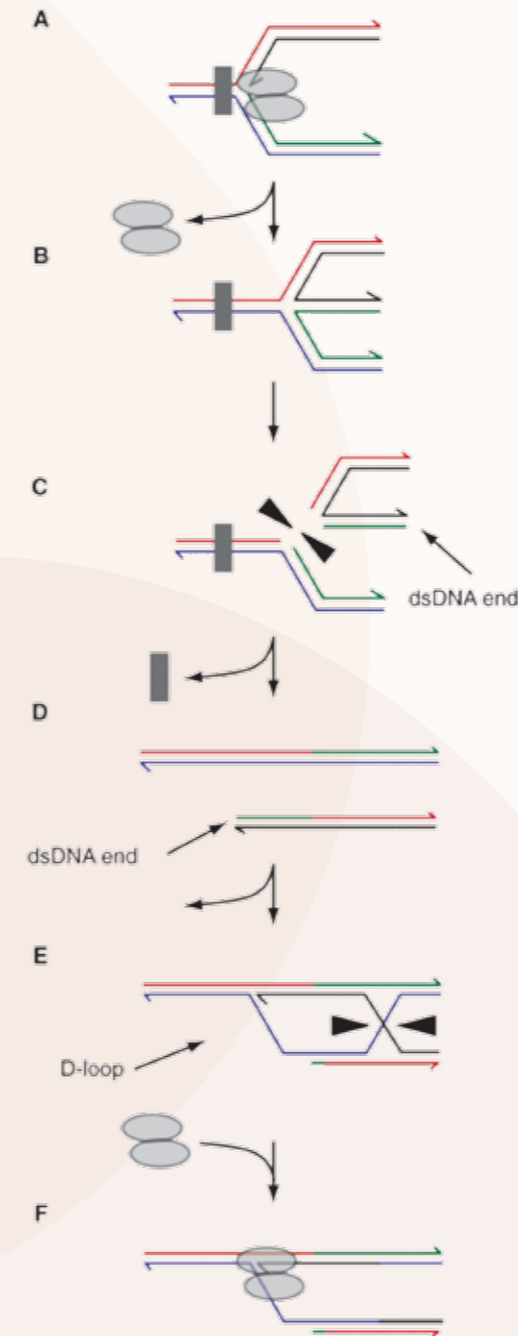

### SELECTED PUBLICATIONS

Carrasco B, Cañas C, Sharples GJ, Alonso JC, Ayora S (2009) The N-terminal region of the RecU Holliday-junction resolvase is essential for homologous recombination. *J Mol Biol* 390:1-9.

Kidane D, Carrasco B, Manfredi C, Rothmaier K, Ayora S, Tadesse S, Alonso JC, Graumann PL (2009) Evidence for different pathways during horizontal gene transfer in competent *Bacillus subtilis* cells. *PLoS Genetics* 5:e1000630.

Lioy S, Pratto V, de la Hoz AB, Ayora S, Alonso JC (2010) Plasmid pSM19035, a model to study stable maintenance in Firmicutes. *Plasmid* 64:1-10.

Restart of DNA replication by fork regression and Holliday Junction (HJ) formation. A) The replisome is stalled. B) The replisome disassembles and the fork regresses. C) HJ resolvases recognise the four-strand intermediate and cleave it. D) The lesion/block is removed, and the dsDNA end processed. E) The resulting end invades a homologous duplex (by the action of a recombinase). The four-strand recombination intermediate is resolved by HJ resolvases. F) The replisome assembles on the new fork.

activities. It interacts with the RecA recombinase and with the RuvB branch migration helicase. We have mapped the region essential for this interaction (1), and observed that RecU is recruited to the competence machinery, probably for modulating RecA activities at the competence pole (2).

	RecU	-	-	100	100	100	100	100	100	nM
RecU	-	-	100	100	100	100	100	100	100	nM
RuvB	-	40	-	40	-	40	-	40	-	nM

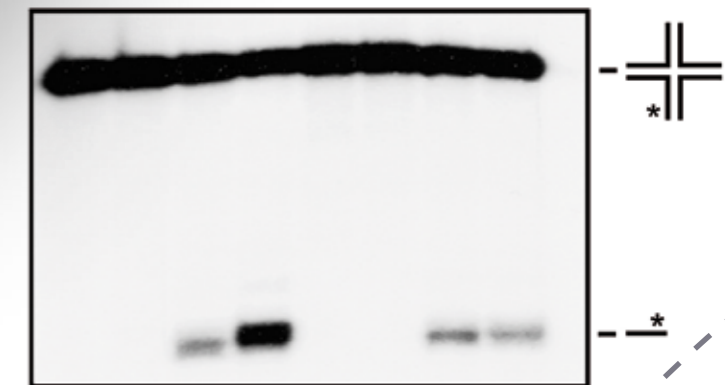

RuvB-ATPS-Mg<sup>2+</sup> fails to stimulate RecUR31A-HJ cleavage, and RecUΔ1-32 is incapable of HJ cleavage. HJ were assembled from four oligonucleotides (80 nt in length), one of which was radiolabelled; the cleavage activity of RecU variants was assayed in the presence of RuvB on a denaturing gel.

## Microbial Biotechnology

LEAD INVESTIGATOR

Jesús Blázquez

POSTDOCTORAL SCIENTISTS

Alfredo Castañeda  
Alexandro Rodríguez-Rojas  
Noelia Alonso



PREDOCTORAL SCIENTISTS

Alejandro Couce  
Thuy Do Thi  
Jerónimo Rodríguez  
Claudia Ibacache

TECHNICIAN

Coloma Costas

STUDENT

Elva Yubero

## Stress and Bacterial Evolution

The major interest of the group is to understand the bacterial responses to stress.

We specifically study hypermutation and hyperrecombination as bacterial "strategies" to speed adaptation to environmental stresses. One of the models used here is antibiotic stress and the development of antibiotic resistance. Our work focuses on both stable and inducible hypermutation/hyperrecombination in *E. coli*, *P. aeruginosa* and *M. smegmatis/tuberculosis*.

We are currently studying:

1. Compensation of stable hypermutation. Once adapted, hypermutable bacteria must decrease (compensate) the high mutation rate to avoid accumulation of deleterious mutations. Our study aims to unveil the molecular mechanisms involved in such compensation.
2. Regulation of stress responses and inducible hypermutation
  - Environmental regulation of mutagenesis
  - Transcriptional regulation of specialized DNA polymerases (belonging to the SOS regulon)
  - Effect of antibiotics on mutation and recombination. Antibiotics as promoters of antibiotic resistance.
3. Hypermutation in bacteria lacking mismatch repair system (MMR) such as *Mycobacterium* and *Streptomyces*. This will allow the use of hypermutant/hyperrecombinant bacteria of industrial interest as biotechnological tools to produce modified biosynthetic pathways.
4. Evolution of resistance to  $\beta$ -lactam antibiotics and the development of new inhibitors of  $\beta$ -lactamases.
5. Molecular bases of bacterial evolution. Combatting antibiotic resistance by preventing evolution (mutation, recombination and horizontal transfer).



### SELECTED PUBLICATIONS

Rodríguez-Rojas A, Blázquez J (2009) The *Pseudomonas aeruginosa* *pfpl* gene plays an antimutator role and provides general stress protection. **J Bacteriol** 191:844-850.

Couce A, Blázquez J (2009) Side effects of antibiotics on genetic variability. **FEMS Microbiol Rev** 33:531-8.

Castañeda-García A, Rodríguez-Rojas A, Guelfo JR, Blázquez J (2009) The Glycerol-3-phosphate permease *GlpT* is the unique fosfomycin transporter in *Pseudomonas aeruginosa*. **J Bacteriol** 191:6968-6974.

Guelfo JR, Rodríguez-Rojas A, Matic I, Blázquez J (2010) A MATE-family efflux pump rescues the *Escherichia coli* 8-oxoguanine-repair-deficient mutator phenotype and protects from oxidative damage. **PLoS Genetics** 6:e1000931.

Rodríguez-Rojas A, Maciá MD, Couce A, Gómez C, Castañeda-García A, Oliver A, Blázquez J (2010) Assessing the Emergence of Resistance: the Absence of Biological Cost *in vivo* May Compromise Fosfomycin Treatments for *P. aeruginosa* Infections. **PLoS One** 5:e10193.

No CAZ (3-5h)



CAZx2 (3h)



CAZx2 (5h)

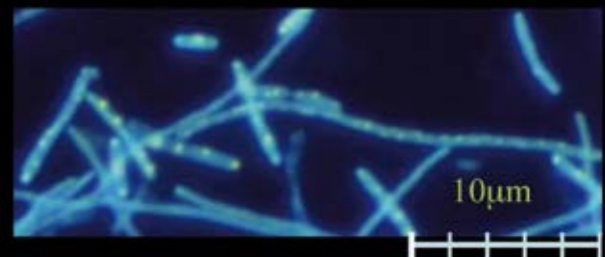

Filamentation of *P. aeruginosa* cells produced by antibiotic treatment. Antibiotic stress elicits morphological, transcriptional and adaptive changes.

## Microbial Biotechnology

LEAD INVESTIGATOR  
**Arturo Calzada**

## Cell Cycle, DNA Replication and Genome Stability in Eukaryotes

We study the regulation of eukaryotic DNA replication.

Defects in the replicative machinery often result in DNA damage and/or genome instability. Our approach is to characterize the molecular abnormalities arising in DNA replication caused by mutations in replication regulators naturally associated to tumorigenesis, to unveil new regulatory pathways and to understand how disease is produced.

Cyclin-dependent kinase (CDK) complexes regulate the initiation of DNA replication, activating fork firing at origins of DNA replication at the G1/S transition, and inhibiting origin licensing to ensure a complete, unique replication per cell cycle. Absence of CDK in G1 is essential for optimal origin licensing. CDK upregulation in G1 causes genome instability and is oncogenic. Recent work by others in yeast and human cells show that CDK upregulation in G1 induces an abnormal, lengthened S phase, with increased DNA damage including double strand breaks. One obvious consequence of increased CDK activity in G1 is reduced origin licensing and firing, as described for a few origins in yeast. What is molecularly different from normal in S phase,

how and where damage is produced, and how it induces genome instability, is poorly understood. We approach these questions in *Saccharomyces cerevisiae* yeast cells, which have proved useful in cell cycle and DNA replication studies.

CDK/cyclin B complexes are maintained inactive in G1, mainly by cyclin degradation of mitotic cyclins by ubiquitination dependent on Cdh1-APC/C (anaphase-promoting complex/cyclosome) and CDK/cyclin inhibition by Sic1 (orthologue to p27 in animal cells) (1, numbers indicate the detail in Fig. 1a), so origin licensing is allowed (2). At start, G1 cyclins are synthesised to activate G1-CDK, which in turn activates S-CDK (3), and inhibits licensing (4). Sic1 inhibits S-CDK (5) activity, necessary for fork firing at G1/S (6), until Sic1 degradation is promoted by G1-CDK (7). Our results with cells lacking Sic1 and/or Cdh1 show, first, that most replication origins studied maintain normal efficiency (resistant origins), and only some (30%) lose efficiency (sensitive origins) to a different extent (Fig. 2, ARS507 and ARS508). Second, origin sensitivity is independent of normal origin firing timing during S phase, origin activity, or origin location on chromosomes, as observed in contiguous origins. Third, cells do not compensate the reduction in forks by firing of silent origins (Fig. 2). Fourth, the rate of gross chromosomal rearrangement (GCR) increases close to the sensitive origin ARS507 (Fig. 2). All these results suggest that when CDK is deregulated, chromosome regions proximal to sensitive origins are more prone to genome instability. Whether GCR occur by attempts to segregate partially unreplicated chromosomes or by fork progression impediments is unknown. Results are summarized in Fig. 1c, in comparison with a normal cell (Fig. 1b).

### SELECTED PUBLICATION

Gambus A, van Deursen F, Polychronopoulos D, Foltman M, Jones R, Edmondson RD, Calzada A, Labib K (2009) A key role for Ctf4 in coupling the MCM2-7 helicase to DNA polymerase alpha within the eukaryotic replisome. *EMBO J* 28:2992-3005.

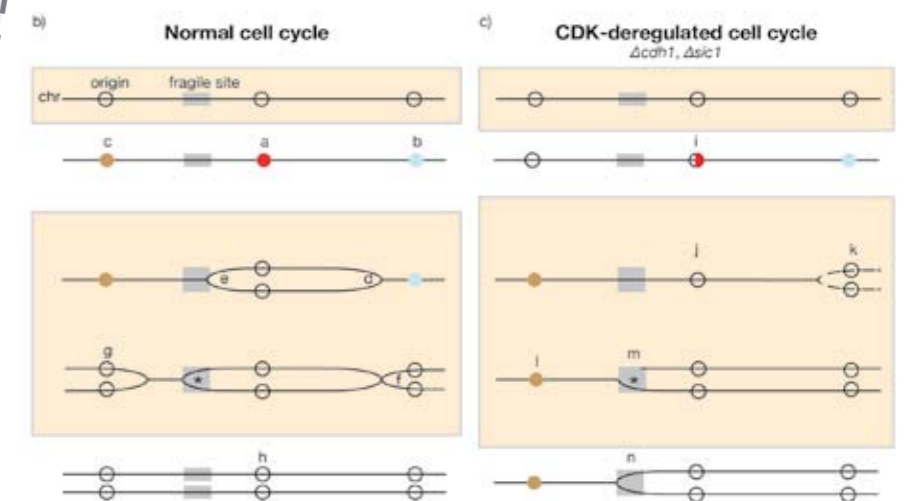
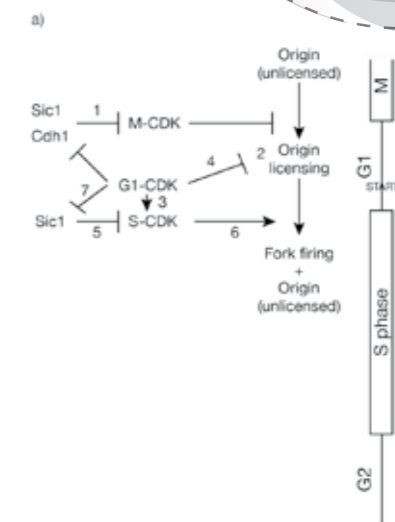

CDK regulation in G1 is important for efficient fork firing at a subset of sensitive origins to prevent chromosome rearrangements in its proximity. a) CDK regulation from M exit to S phase in *S. cerevisiae* cells, in origin activation. Numbers are explained in the text. b) and c), models resuming data from figure 2. b) In normal cells, early (a) and late (b) firing origins, and silent origins (c) are licensed in G1. In S phase, early origins initiate two divergent forks migrating (d) or pausing (e) depending on chromatin features. Late origins fire later in S phase (f). If fork collapse occurs (g), silent origins fire (g) to avoid unreplicated sequences after S phase ends. Replication reroutes origins unlicensed (h), cl in CDK deregulated cells, licensing in G1 is incomplete at sensitive origins (i), probably due to reduced G1 length either by inefficient M-CDK inhibition or premature S-CDK activation. Unfired origins (j) change the replication dynamics at that particular region that is now replicated by forks fired at resistant proximal origins (k). Silent origins do not fire to compensate unfired origins (l). Chromosomal rearrangements increase in the area normally replicated by a CDK-deregulated sensitive-origin, possibly as a consequence of DNA breaks (m) or regions left unreplicated in S phase (n). Open circles, unlicensed origins. Closed circles, licensed origins.



PREDOCTORAL SCIENTISTS  
**Pilar Ayuda-Durán**  
**Fernando Devesa Geanini**

Replication dynamics and chromosomal stability at the left arm of chromosome V in *S. cerevisiae* cells. a) left arm of chromosome V including coordinates from the telomere, and location of replication of real (ARS503, 504, 507, 508) and putative (proARS504, 506) origins. b) Origin activity by two dimensional agarose electrophoresis of DNA to measure origin efficiency, where the intensity of the external arc indicates when the origin is active, and the internal arc indicates when the origin is inactive; comparison of both arcs determines origin efficiency. A white arrowhead indicates when the origin loses efficiency (the internal arc gains signal, and the external arc loses signal) for cells of the strains on the left. c) Estimation of the Gross Chromosomal Rearrangements rate for the indicated strains (Chen and Kolodner, 99, *Nature Genet.* 23,81-85).

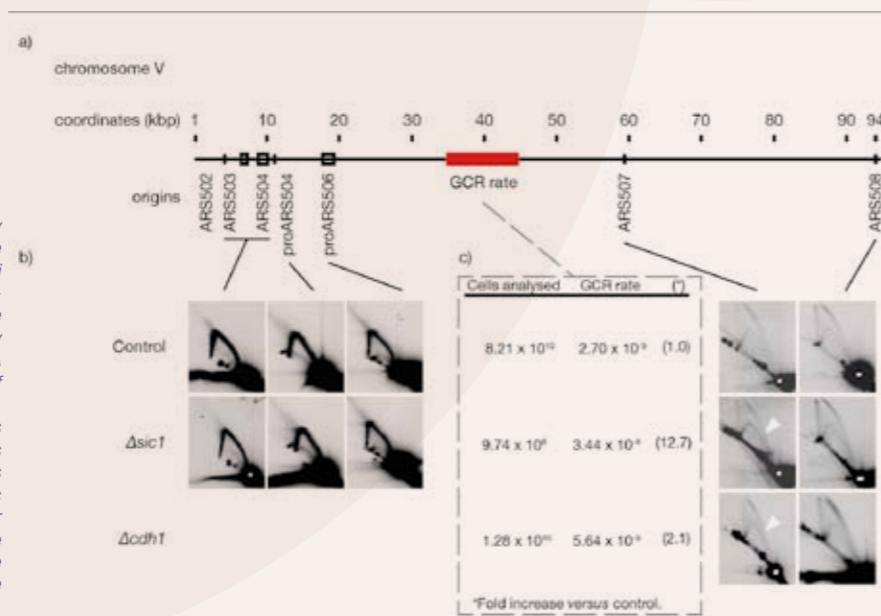

## Microbial Biotechnology

LEAD INVESTIGATOR

Luis Ángel Fernández  
Herrero

POSTDOCTORAL SCIENTISTS

Gustavo Bodelón González  
Carmen Palomino del Castillo



PHD STUDENTS

Elvira Marín Muñoz  
Ana Blanco Toribio  
David Ruano Gallego  
Carlos Piñero Lambea  
Valencio Salema

TECHNICIAN

Henar Petit Balmaseda

## Protein Secretion and Antibody Expression

Our group conducts both **basic and biotech-oriented research** aimed to understand and exploit protein secretion in *E. coli* and other **Gram-negative bacteria** (proteobacteria).

Our basic research focuses on the molecular mechanisms that bacterial pathogens employ for the secretion of proteins (e.g. cytotoxins, proteases, adhesins) and for the assembly of cell surface organelles (e.g. fimbriae) that participate in bacterial virulence. We focus especially on those proteins and surface organelles secreted and assembled by **pathogenic *E. coli* strains** like enteropathogenic (EPEC), enterohemorrhagic (EHEC) and uropathogenic (UPEC) *E. coli* strains. The biotechnological projects exploit these protein secretion systems for the development of novel **expression and selection technologies for recombinant antibodies** in non-pathogenic commensal and laboratory *E. coli* strains. Among the recombinant antibody formats available (e.g. single-chain Fv, Fab, Fc-fusions, etc.), we focus on single-domain antibodies (**sdAbs**) or **nanobodies**, the smallest antibody fragment known-to-date (~15 kDa) with full antigen-binding capacity. Nanobodies are based on a single V<sub>H</sub> domain obtained by recombinant DNA technology from heavy-chain-only antibodies from camelids (e.g. dromedaries, llamas). Despite the lack of a paired V<sub>L</sub> domain, nanobodies show high-affinity and specificity for their cognate antigens. In addition they are highly similar to human V<sub>H</sub>3 sequences, making them excellent candidates for multiple applications, including human therapy.

Some of our current projects are:

The secretion mechanism of the bacterial type V secretion system (T5SS) and its application for the bacterial display of single-domain antibodies. The T5SS include proteins with "self-translocation" capacity across the outer membrane like the Intimin-Invasin family and the so-called autotransporters (ATs), which are the major family of proteins secreted by Gram-negative bacteria. ATs have distinct biological functions important during the pathogenesis of the producer

microorganism (e.g. proteolysis of host proteins and antibodies, cytotoxicity of host cells, adhesion to host tissue, etc). In addition to investigate the secretion mechanism of ATs, we are exploiting the translocator domains of T5SSs to display nanobodies on the surface of *E. coli* for selection of binders against specific antigens (bacterial display).

**Assembly of type 1 fimbriae.** Type 1 fimbriae are thin proteinaceous filaments assembled on the surface of *E. coli* cells by the ordered polymerization of a major protein subunit (FimA) and several minor protein subunits (FimF, FimG, FimH) assembled by the chaperone-usher pathway. Type 1 fimbriae and FimH adhesin are essential for effective colonization and invasion of the epithelial cells of the urinary bladder by UPEC strains. We found that the N-terminal lectin domain of FimH is recognized by the fimbrial usher FimD in order to initiate the assembly the adhesin and the polymerization of the fimbrial filament. The mechanism of activation of FimD by the N-lectin domain of FimH is currently under investigation.

**Injection of nanobodies from *E. coli* into human cells.** We are employing the type III protein secretion system (T3SS) from EPEC and EHEC strains, to directly deliver single-domain recombinant antibodies from *E. coli* cells into the cytosol of human cells. During infection T3SSs act as molecular syringes for the translocation of proteins from bacteria into eukaryotic cells. *E. coli* injection of nanobodies does not require bacterial invasion of the eukaryotic cell or the transfer of any genetic material.

Structure of conventional and heavy-chain only antibodies, comparing the structure of different recombinant antibody fragments, including single chain Fv (scFv) and single-domain antibodies (sdAbs).

## SELECTED PUBLICATIONS

Bodelón G., Marín E., and L.A. Fernández\* (2009) "Role of periplasmic chaperones and BamA (YaeT/Omp85) for folding and secretion of Intimin from enteropathogenic *E. coli* strains" *Journal of Bacteriology* 191:5169-5179.

Marín E., Bodelón G., and L.A. Fernández\* (2010) "A comparative analysis of the biochemical and functional properties of C-terminal domains of autotransporters" *Journal of Bacteriology* 192: 5588-5602.

Blanco-Toribio A., Muyldermans S., Frankel G, and L.A. Fernández\* (2010) "Direct injection of single-domain antibodies from *E. coli* into human cells" *PLoS ONE* 5(12): e15227.

## Antibody fragments

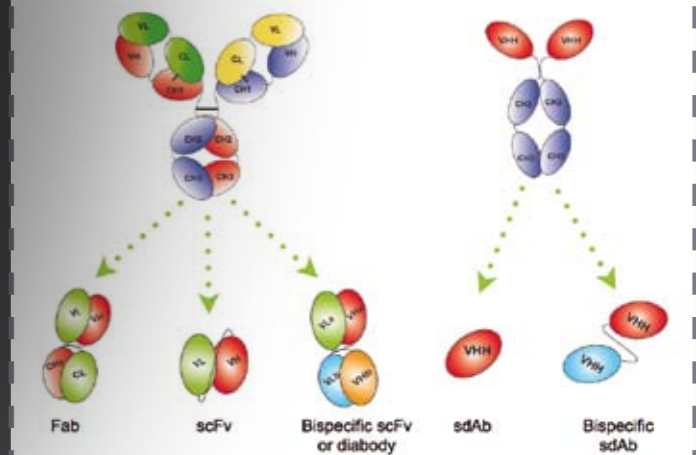

Scanning electron micrograph of human HeLa cells infected in vitro with attenuated EPEC bacteria carrying a functional T3SS injecting sdAbs into the cytoplasm of the human cell.

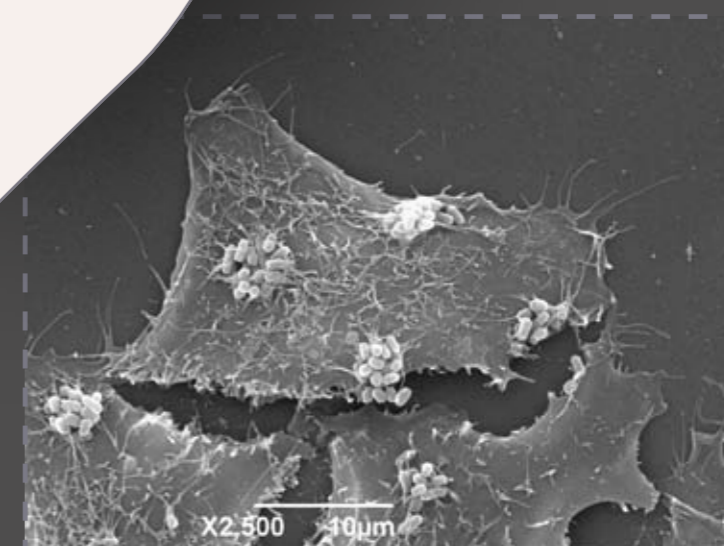

## Microbial Biotechnology

LEAD INVESTIGATOR

Francisco  
García-del Portillo

SENIOR SCIENTIST

María Graciela Pucciarelli

POSTDOCTORAL SCIENTISTS

Javier Mariscotti  
Natalia Martínez-Soria  
Jesús Gonzalo-Asensio  
Álvaro D. Ortega



PREDOCTORAL SCIENTISTS

Fátima García-Quintanilla  
Lorena Domínguez-Acuña  
Laura Botello  
Gadea Rico

TECHNICIANS

M. Laura Navarro  
Diana Barroso  
M. Carmen Morán

Scanning electron microscope images denoting the massive membrane remodelling concomitant to the entry of wild-type *Salmonella* into NRK49F rat fibroblasts (A-B). Entry of the  $\Delta$ SPI-1 mutant takes place by a zipper-like mechanism involving discrete filopodia and lamellipodia (C-E) (adapted from Alastui et al. *Infect Immun* (2010) 78:2700).

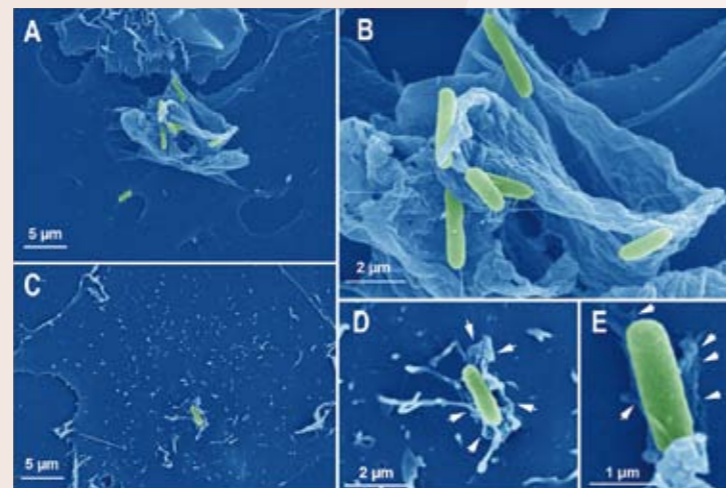

## Intracellular Bacterial Pathogens

Using *Salmonella* and *Listeria* as models, our group attempts to decipher the lifestyle of bacterial pathogens inside eukaryotic cells and the host responses to these intracellular infections.

We have progressed in the characterization of small regulatory RNA expressed by non-growing intracellular *Salmonella* inside cultured fibroblasts.

Some of these sRNA were found to be upregulated in intracellular bacteria only at late post-infection times. This expression pattern suggests that a subset of sRNA might play a role in long-adaptation of intracellular bacteria to limited nutrient availability and stress. A novel sRNA was also identified in the virulence plasmid pSLT. This sRNA, named 0995, is expressed at high levels by non-growing intracellular bacteria. Current effort is focused in defining the targets of these sRNA and the underlying regulatory mechanisms. We also characterized, at the molecular level, the entry process of *Salmonella* into fibroblasts. This process differs from that described for epithelial cells. A representative feature was the dispensability of the GTPase RhoG for the actin cytoskeleton remodelling that promotes bacterial entry into fibroblasts. We also found differences in the extent to which membrane ruffling is elicited and the

strict requirement for the type III secretion system encoded in the *Salmonella-pathogenicity* island 1 (SPI-1).

*Listeria monocytogenes* surface proteins associated to the cell wall. In our effort to characterize the biological role of the *L. monocytogenes* surface protein family containing a C-terminal LPXTG motif, we continued the proteomic analysis of cell wall material isolated from bacteria growing in different conditions. We purified enough material from bacteria growing inside eukaryotic cells and identified the members of this large protein family that are synthesized by intracellular bacteria. In collaboration with other European laboratories, we also completed the series of isogenic mutants deficient in each of the 41 LPXTG proteins encoded in the genome of the *L. monocytogenes* strain EGD-e. Cell wall proteome studies in each of these mutants revealed that lack of certain LPXTG proteins impairs the activity of the sigma-B (SigB)-dependent regulon. These data connect cell wall integrity with the phosphorylation cascade that dictates the physiological state of the SigB protein. Current efforts are directed to dissecting the exact mechanisms connecting the function of this group of LPXTG proteins to the activity of the SigB regulon. In addition, we defined the features of the sorting motif recognized in the two proteins substrates of the alternative sortase of *L. monocytogenes*, SrtB.

## SELECTED PUBLICATIONS

Alastui A, Pucciarelli MG, García-del Portillo F (2010) *Salmonella* invades fibroblasts by multiple routes differing from the entry into epithelial cells. *Infect Immun* 78:2700-2713.

Paradela A, Marcilla M, Navajas R, Ferreira L, Ramos-Fernández A, Fernández M, Mariscotti JM, García-del Portillo F, Albar JP (2010) Evaluation of isotope-coded protein labeling (ICLP) in the quantitative analysis of complex proteomes. *Talanta* 80:1496-1502.

López-Garrido J, Cheng N, García-Quintanilla F, García-Del Portillo F, Casadesús J (2010) Identification of the *Salmonella enterica* *damX* gene product, an inner membran protein involved in bile resistance. *J Bacteriol* 192:893-895.

Mariscotti JF, García-Del Portillo F, Pucciarelli MG (2009) The *Listeria monocytogenes* sortase-B recognizes varied amino acids at position two of the sorting motif. *J Biol Chem* 284:6140-6146.

Mariscotti JF, García-Del Portillo F (2009) Genome expression analyses revealing the modulation of the *Salmonella* Rcs regulon by the attenuator IgaA. *J Bacteriol* 191:1855-1867.

Actin rearrangements triggered by *Salmonella enterica* serovar Typhimurium in NRK49F rat fibroblasts. Entry into fibroblasts of bacteria lacking the *Salmonella-pathogenicity* island 1 ( $\Delta$ SPI-1) takes places without major actin remodelling.

wild-type

$\Delta$ SPI-1

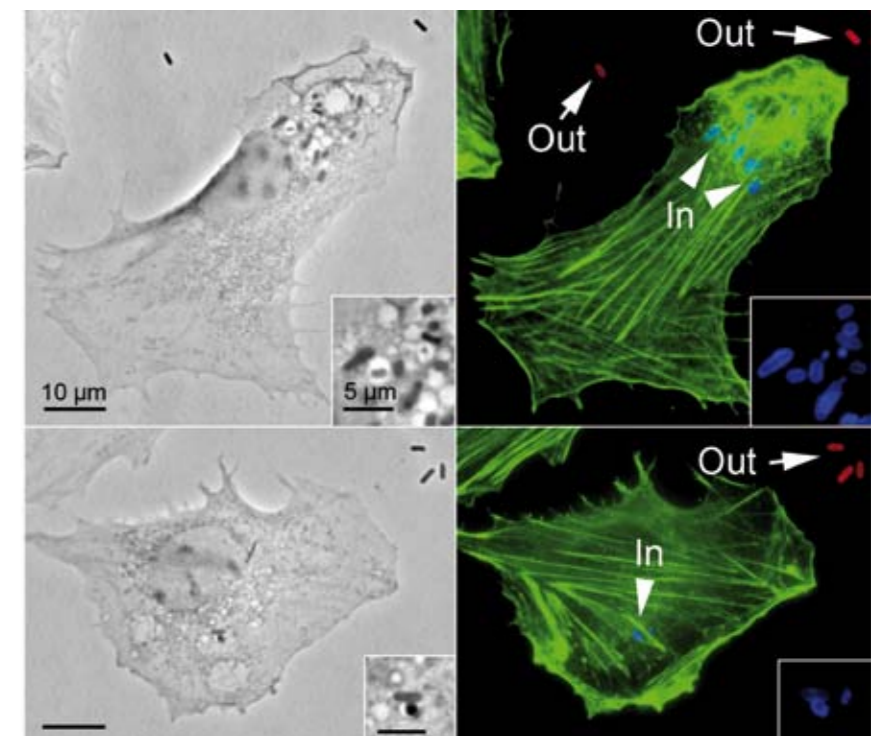

## Microbial Biotechnology

LEAD INVESTIGATOR

**Francisco Malpartida Romero**

POSTDOCTORAL SCIENTIST

**Elena M. Seco Martín**

PREDOCTORAL SCIENTISTS

**Domingo Miranzo Navarro**  
**Leticia Escudero Crujera**



TECHNICIANS

**Trinidad Cuesta Velasco**  
**Cristina Nieto Higuera**

VISITORS

**Leticia Esteban Tejeda**  
**Belén Cabal**  
**Miriam Miranda Fernández**  
**Angela Vara Gazapo**

## Molecular Genetics of *Streptomyces*

Our group is currently focused on characterization of bioactive compounds with antimicrobial activities.

Materials from two different sources were analyzed: antifungal compounds of biosynthetic origin (polyene macrolides) and inorganic material with a broad antimicrobial spectrum (nano-structured mineral composites).

In recent last decades, systemic fungal infections are becoming a serious and increasing threat to human health. Unlike the antibacterials, the available arsenal of antifungal drugs is very limited and thus, new chemical structures with antimicrobial activities are urgently needed. The isolation of biosynthetic genes leading to bioactive metabolite production has proved to be a valuable tool for designing new chemical structures by genetic/metabolic engineering of microbial strains producers of complex bioactive metabolites. The polyene macrolides have been consid-

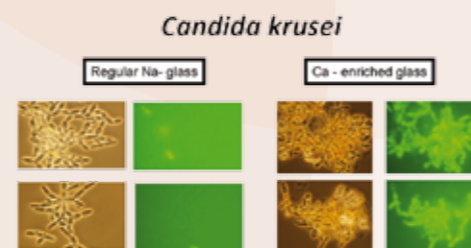

Bioactive polyene structures isolated from recombinant *S. diastaticus* var. 108 strains. Some polyene structures were deduced to be present in the fermentation broths (?).

ered in recent decades as secondary metabolites with excellent antifungal activity; amphotericin B is undoubtedly the "golden" drug of this family. Nevertheless, the use of this drug in clinical therapy, as well as of other polyenes, is restricted due to their associated cytotoxicity. Aimed at reducing such severe side effects, several approaches were taken for generating new and safer derivative drugs

from these old bioactive compounds: chemical synthesis to produce semisynthetic derivatives, new formulations for safely delivering drugs during systemic infection, and genetic manipulation of biosynthetic genes to generate new derivatives from previous bioactive drugs. By targeting genes of the rimocidin biosynthetic pathway and the tailoring activity of a carboxamide synthase from *S. diastaticus* var. 108, ten new polyene derivatives were isolated from these recombinant strains.

In addition to organic compounds of biosynthetic origin, several inorganic materials were analyzed as antimicrobial agents. Microbial contamination is not only a serious threat that compromises human and animal health; several industrial processes are also affected by uncontrolled growth of microorganisms. In some environmental conditions, the use of biocides of biosynthetic origin can be unreliable for controlling undesirable microbial populations; the inorganic antimicrobials seemed to be, at least intuitively, more active and stable in those circumstances. In the last few years, several bioactive materials have been tested against a large range of microbial cultures, including nano-structured materials of defined composition. Most are very abundant in nature and possibly suitable for use in many socio-economic areas, particularly when efficiency as a biocide, chemical stability and environment protection are needed.

Micrographs of an oxonol-guided antimicrobial test. The green fluorescence of the oxonol indicator shows the failure of the electrochemical gradient across the membrane. The yeast culture was treated with microparticles of regular windows glasses (left) or Ca<sup>++</sup>-enriched glasses particles.

## SELECTED PUBLICATIONS

Seco EM, Miranzo D, Nieto C, Malpartida F (2010) The pcsA gene from *Streptomyces diastaticus* var. 108 encodes a polyene carboxamide synthase with broad substrate specificity for polyene amides biosynthesis. **Appl Microbiol Biotechnol** 85:1797-1807.

Esteban-Tejeda L, Malpartida F, Pecharrómán C, Moya JS (2010) High antibacterial and antifungal of silver monodispersed nanoparticles embedded in a glassy matrix. **Adv Eng Mater** 12:292-297.

Miranzo D, Seco EM, Cuesta T, Malpartida F (2010) Isolation and characterization of pcsB, the gene for a polyene carboxamide synthase that tailors pimarcina into AB-400. **Appl Microbiol Biotechnol** 85:1809-1819.

Cabal B, Torrecillas R, Malpartida F, Moya JS (2010) Heterogeneous precipitation of silver nanoparticles on kaolinite plates. **Nanotechnology** 21:475705.

Esteban-Tejeda L, Malpartida F, Esteban-Cubillo A, Pecharrómán C, Moya JS (2009) Antibacterial and antifungal activity of a soda-lime glass containing copper nanoparticles. **Nanotechnology** 20: 505701.

## PATENTS

F. Malpartida, E.M. Seco Martín and D. Miranzo. Macrólidos polienos con actividad antimicrobiana y su procedimiento biotecnológico de obtención. **P200930550**.

J. Moya, L. Esteban, C. Pecharrómán, F. Malpartida. Polvo de composición vítrea con actividad biocida. **P200931137**.

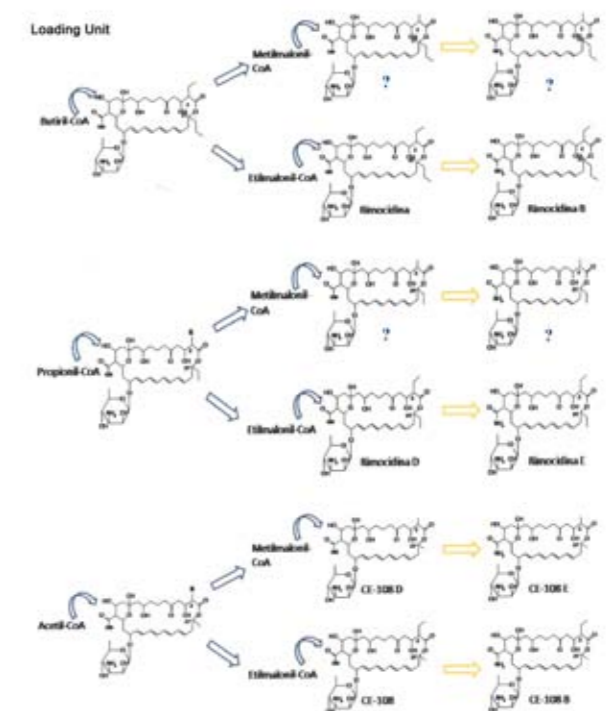



## Microbial Biotechnology

LEAD INVESTIGATOR

José Pérez Martín

POSTDOCTORAL SCIENTISTS

Isabel Álvarez-Tabares  
Natalia Carbó Silva

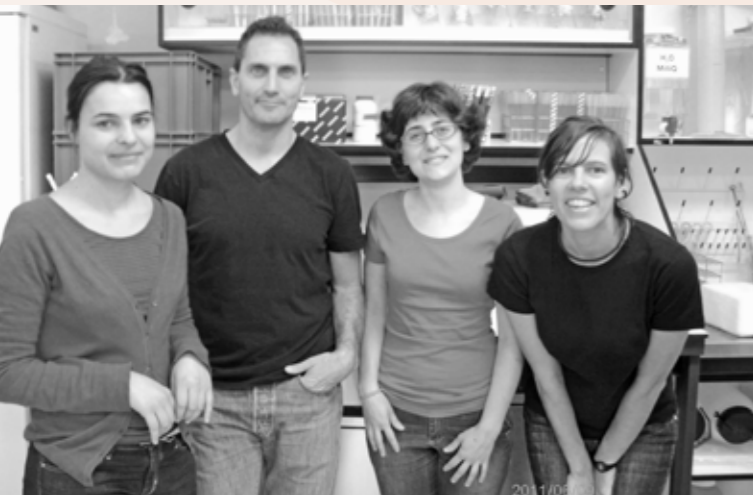

PREDOCTORAL SCIENTISTS

de Sena Tomas  
Sónia Castanheira  
Fernando Devesa

## Molecular Mechanisms of Fungal Virulence

Our group hypothesised that cell cycle regulation would be likely to provide control points for infection development by fungal pathogens.

We consider that the cell cycle has to be adjusted in response to both environmental and developmental signals, and that the integration of both classes of signals by the cell machinery will result in an outcome that define fungal fate: in the case of pathogenic fungi, whether



Activation of the cell wall damage pathway induces strong morphological changes. Cells expressing a constitutive kinase (*mkk1<sup>DD</sup>*) display morphological defects (additional details in Carbo & Perez-Martin 2010).

or not they enter the virulence program. The corn smut fungus *Ustilago maydis* is an excellent system in which to address these relationships between cell cycle, morphogenesis and virulence. Induction of the virulence program in this fungus implies not only strong morphological changes (bud to hypha transition) but also genetic changes (haploid

Scientific Report 09-10  
Centro Nacional de Biotecnología CNB

to dikaryotic transition). Consequently, accurate control of the cell cycle and morphogenesis is predicted during these transitions.

To achieve the specific aims of this hypothesis, the scientific objectives have been framed in two major groups. The first group of objectives addresses how the cell cycle is modified during the pathogenic phase, whereas the second addresses the importance of morphogenetic pattern in the cell cycle responses to environmental signals transmitted by MAPK cascades.

Our research offers original opportunities to address the molecular basis of fungal virulence from a different point of view, which at the same time is complementary to previous approaches in the field more focussed on the study of signal transduction and transcriptional changes.

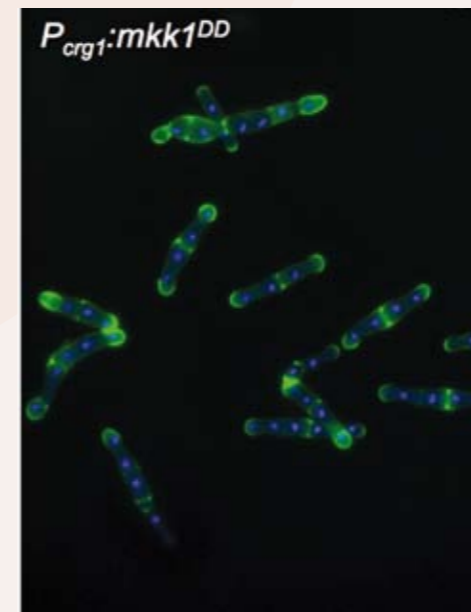

## SELECTED PUBLICATIONS

Carbó N, Pérez-Martín J (2010) Activation of the Cell Wall Integrity pathway promotes escape from G2 in the fungus *Ustilago maydis*. *PLoS Genet* 6:1001009.

Alvarez-Tabares I, Pérez-Martín J (2010) Septins from the phytopathogenic fungus *Ustilago maydis* are required for proper morphogenesis but dispensable for virulence. *PLoS One* 5:e12933.

Mielnichuk N, Sgarlata C, Pérez-Martín J (2009) A role for the DNA-damage checkpoint kinase Chk1 in the virulence program of the fungus *Ustilago maydis*. *J Cell Sci* 122:4130-4140.

Pérez-Martín J (2009) DNA-damage response in the basidiomycete fungus *Ustilago maydis* relies in a sole Chk1-like kinase. *DNA Repair* 8:720-731.

Cánovas D, Pérez-Martín J (2009) Sphingolipid biosynthesis is required for polar growth in the dimorphic phytopathogen *Ustilago maydis*. *Fungal Genet Biol* 46:190-200.

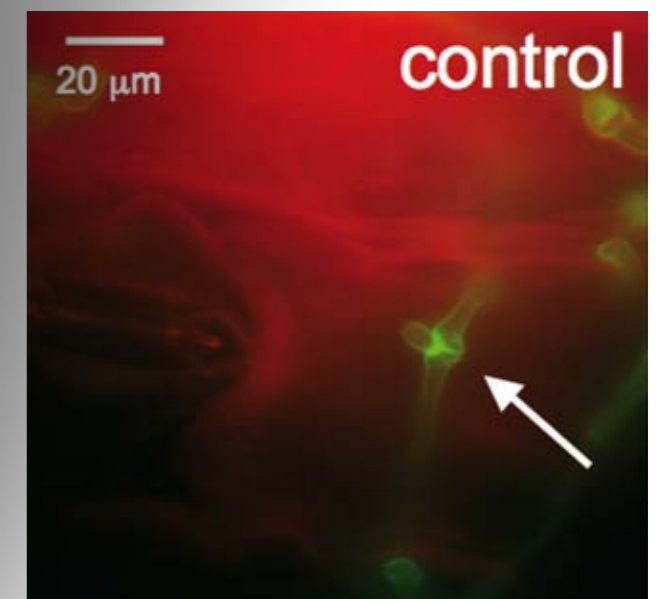

The DNA damage pathway is required for in planta proliferation. Mutant fungi lacking the checkpoint kinase Chk1 proliferate aberrantly in corn plants (additional details in Mielnichuk et al. 2009).

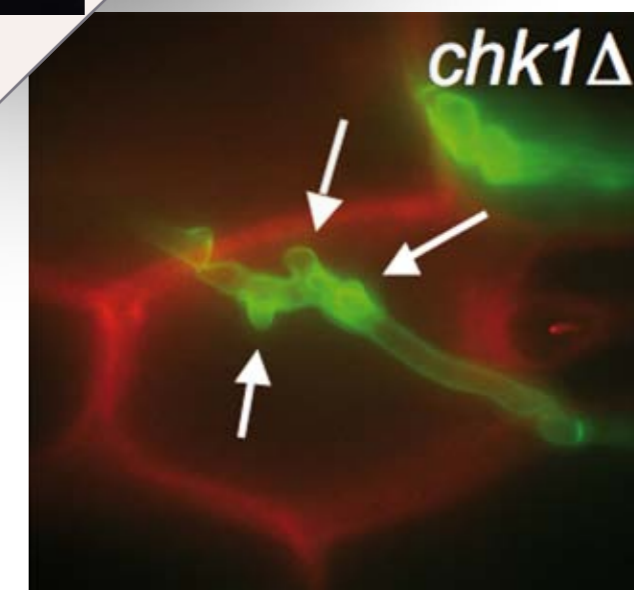

## Microbial Biotechnology

LEAD INVESTIGATOR

José Luis Martínez

POSTDOCTORAL SCIENTISTS

Carolina Alvarez-Ortega  
Blanca Sánchez  
Alicia Fajardo



PREDOCTORAL SCIENTISTS

Leonor Garmendia  
Jorge Olivares  
Guillermo García  
Felipe Lira

MASTER STUDENTS

Fernando Corona  
Fabiola Salgado

TECHNICIAN

Trinidad Cuesta

## Opportunistic Pathogens

Infectious diseases remain among the major causes of human death in the world.

Several infections at hospitals are due to opportunistic pathogens, microorganisms that rarely infect healthy people, but are a frequent cause of infection in people with basal diseases, who are immunodepressed or debilitated.

Environmental bacteria, frequently antibiotic resistant, constitute a large percentage of those pathogens. Our work focuses on understanding the mechanisms of virulence and resistance, as well as their possible crosstalk, of these pathogens.

Within this scope, in the last two years, we have been defining those genes whose mutation changes the phenotype

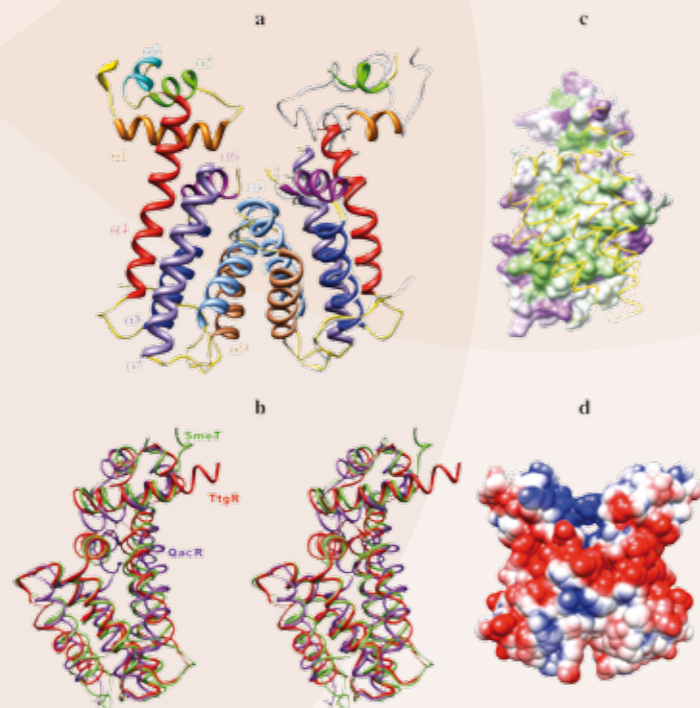

Structure of SmeT. 1a) Ribbon representation of SmeT; helices 1-9 are shown in different colours and are labelled only in subunit A. Subunit A is superposed onto subunit B and is shown in grey. 1b) Stereo view of the structural comparison between SmeT (green), QacR (magenta, ID code 1JUP) and TtgR (red, ID code 2UXU). The extended N and C termini of SmeT are shown. 1c) Conservation of the hydrophobic character of the residues in the interface of the SmeT dimer. The figure was prepared using HOMOLMAPPING, based on alignment of 288 sequences from members of the TetR family prepared by M-Coffee. Residues in green have a conserved hydrophobic character; residues in magenta do not. Subunit B is represented as a yellow backbone tube to show the dimerisation area. 1d) Electrostatic surface potential of the SmeT dimer. Since the model is incomplete, subunit A was superposed onto subunit B and the dimer thus generated was used for calculations. Electrostatic potential was calculated by APBS and is mapped on the solvent-accessible surface by CHIMERA. Electrostatic potential values range from positive (blue: 5 kT/e) to negative (red: -5 kT/e) (from Hernandez et al. 2009. J Biol Chem 284:14428).

of antibiotic susceptibility of *Pseudomonas aeruginosa*. As a result, we have selected nearly three hundred genes for future analysis and are currently studying whether those mutations that challenge intrinsic resistance also alter the virulence of *P. aeruginosa*. We found that mutations in several genes encoding proteins from different categories that include multidrug efflux pumps, two component systems, metabolic enzymes or global regulators, simultaneously alter the antibiotic susceptibility and the virulence of *P. aeruginosa*. One of these is Crc, a global regulator involved in *Pseudomonas* carbon metabolism. We found that a *crc*-defective mutant is more susceptible to several antibiotics and expresses several virulence determinants at lower levels than the wild-type strain. These results indicate that the resistance to antibiotics and the virulence of *P. aeruginosa* are intrinsically linked to bacterial metabolism.

Another opportunistic pathogen we are working with is *Stenotrophomonas maltophilia*, which is characterized by its intrinsic low susceptibility to several antibiotics. Part of this low susceptibility relies on the expression of chromosomally-encoded multidrug efflux pumps. Expression of *smeDEF* is downregulated by the SmeT repressor, encoded upstream of *smeDEF* in its complementary DNA strand. We determined the crystal structure of SmeT and analysed its interactions with its cognate operator. SmeT behaves as a dimer and presents some common structural features with other TetR regulators. At difference from other TetR proteins for which the structure is available, SmeT turned out to have two extensions at the N and C termini that might be relevant to its function. *In vitro* studies showed that SmeT binds to a 28 bp pseudopalindromic region, forming two complexes. This operator region overlaps the promoters of *smeT* and *smeDEF*, a finding consistent with a role for SmeT in simultaneously downregulating *smeT* and *smeDEF* transcription.

## SELECTED PUBLICATIONS

Linares JF, Moreno R, Fajardo A, Martínez-Solano L, Escalante R, Rojo F, Martínez JL (2010) The global regulator Crc modulates the metabolism, the susceptibility to antibiotics and the virulence of *Pseudomonas aeruginosa*. *Environ Microbiol* 12: 3196-3212.

Alvarez-Ortega C, Eiegand I, Olivares J, Hancock RW, Martínez JL (2010) Genetic determinants involved in the susceptibility of *Pseudomonas aeruginosa* to  $\beta$ -lactam antibiotics. *Antimicrob Agents Chemother* 54:4159-4167.

Hernández A, Maté MJ, Sánchez-Díaz PC, Romero A, Rojo F, Martínez JL (2009) Structural and functional analysis of SmeT, the repressor of the *Stenotrophomonas maltophilia* multidrug efflux pump *smeDEF*. *J Biol Chem* 284:14428-14438.

Martínez JL, Sánchez MB, Martínez-Solano L, Hernández A, Garmendia L, Fajardo A, Alvarez-Ortega C (2009) Functional role of bacterial multidrug efflux pumps in the microbial natural ecosystems. *FEMS Microbiol Rev* 33:430-449.

Martínez JL, Fajardo A, Garmendia L, Hernández A, Linares JF, Martínez-Solano L, Sánchez MB (2009) A global view on antibiotic resistance. *FEMS Microbiol Rev* 33:44-65.

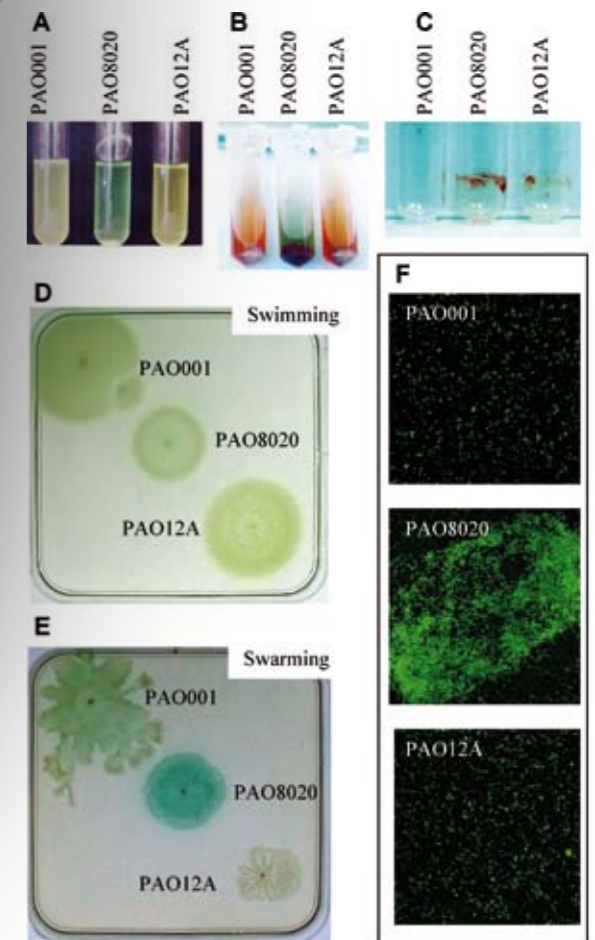

Effect of Crc on the multicellular behaviour of *P. aeruginosa*. In all panels, PAO001 is the wild-type strain, PAO8020 is the *crc* mutant and PAO12A corresponds to PAO8020 containing a plasmid encoding Crc. A) As shown, the *crc* mutant overproduced the green phenazine pyocyanine, attaches to the air-liquid interface and forms large bacterial aggregates (see bottom of tube containing the *crc* mutant). Phenotypes are restored after complementation in PAO12A. B) Cells were grown in LB medium, stained with Congo Red and centrifuged. Congo Red is retained only by the *crc* mutant PAO8020 pellet, indicating EPS production by this strain. C) Cells attached to the walls of culture tubes were stained with Congo Red to study the presence of exopolysaccharides in the multicellular structure. D, E) Effect of Crc on *P. aeruginosa* motility. Lack of *crc* impaired both swimming (D) and swarming (E) motility of *P. aeruginosa*. Swimming motility was fully restored after expression of plasmid-encoded Crc (strain PAO12A), whereas for swarming, complementation with Crc restored formation of the protrusions typical of this type of movement (although colony size was not fully restored). F) *P. aeruginosa* aggregation was visualized by confocal microscopy. Lack of *crc* induced strong bacterial clumping. The phenotype was fully restored after expression of plasmid-encoded Crc (from Linares et al. 2010. *Environ Microbiol* 12:3196).

## Microbial Biotechnology

LEAD INVESTIGATOR

Rafael P. Mellado

POSTDOCTORAL SCIENTISTS

Sonia Gullón  
Nuria Antón  
Jorge Barriuso



PREDOCTORAL SCIENTISTS

Daniel Rozas  
Esther Isabel García  
Rebeca López Vicente

TECHNICIAN

Silvia Marín

## Heterologous Gene Expression and Secretion in Gram-positive Bacteria of Industrial Application

The group has traditionally focused its research on the physiological and molecular characterisation of the main protein secretion mechanism (Sec system) of the soil Gram-positive bacteria of the *Streptomyces* genus, namely *S. lividans* and *S. coelicolor*.

These are widely used in industry as efficient producers of extracellular hydrolytic enzymes and other compounds of industrial interest. Deficiency in the translocase complex (SecG mutant strain) or the major type I signal peptidase (SipY mutant strain) function in *S. lividans* results in a group of genes seemingly regulated in the same way when the translocation process of extracellular proteins is restricted, or when extracellular protein processing is compromised, including the absence of secretory protein production in both cases and a sporulation deficient bald phenotype. Transcriptional profiling and proteomic analyses of both *S. lividans* strains revealed a set of equally regulated *bld*-related genes. A bald phenotype is acquired in both mutant strains by downregulation of *bld* chain genes. Although a common regulator has not yet been identified, most of the commonly regulated genes can be linked directly or indirectly to the *bld* cascade, strongly suggesting its involvement in the cell response to the secretory defect of both mutant strains.

Sporulation deficiency. *SecG* and *SipY* deficient strains fail to sporulate in R5 medium (A), being unable to differentiate their aerial hyphae into spores, as determined by scanning electron microscopy (B).

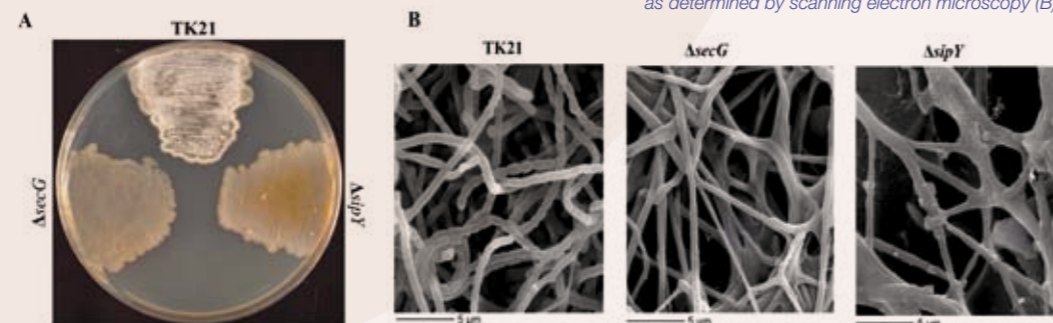

A *S. coelicolor* two-gene operon encodes a two-component system: a histidine-kinase sensor and a response regulator protein. Propagation of the regulatory gene in high copy number results in overproduction of several extracellular proteins, as well as eliciting a partial stringent response and an altered pattern of antibiotic synthesis in the bacterial cell, as determined by proteomic and transcriptomic analyses. This two-component system is currently under study in *S. coelicolor*, as it seems to influence various processes characterised by the transition from primary to secondary metabolism.

The laboratory has started a new research line focused on molecular monitoring of the rhizobial communities of transgenic plants. Rhizobacterial communities of transgenic maize engineered to express the *Bacillus thuringiensis* Cry toxin (Bt maize) have been monitored for a number of years in three agricultural soils, using commercially available DNA microarrays containing genome-wide spotted oligonucleotides that encompass the soil bacteria *B. subtilis* and *S. coelicolor*. The results showed that genome-wide DNA arrays could be a useful tool for molecular monitoring of rhizobacterial communities to assess potential environmental risk associated with cultivation of transgenic plants.

We compared the effect of glyphosate (RoundupPlus), a post-emergency applied herbicide, and HarnessGTZ, a pre-emergency applied herbicide, on the rhizobacterial communities of genetically modified NK603 glyphosate-tolerant maize. The potential effect was monitored by direct amplification, cloning and sequencing of soil DNA encoding 16S rRNA, rhizobacterial DNA hybridisation to commercially available genome-wide microarrays from the soil bacterium *S. coelicolor*, and high throughput DNA pyrosequencing of the bacterial DNA coding for the 16S rRNA hypervariable V6 region. The results strongly suggest that both herbicides do affect the maize rhizobacterial communities, with glyphosate being, to a great extent, the environmentally less aggressive.

### SELECTED PUBLICATIONS

Val G, Marín S, Mellado RP (2009) A sensitive method to monitor *Bacillus subtilis* and *Streptomyces coelicolor*-related bacteria in maize rhizobacterial communities: The use of genome-wide microarrays. *Microb Ecol* 58:108-115.

Barriuso J, Marín S, Mellado RP (2010) Effect of the herbicide glyphosate on glyphosate-tolerant maize rhizobacterial communities: a comparison with pre-emergency applied herbicide consisting of a combination of acetochlor and terbutylazine. *Environ Microbiol* 12:1021-1030.

### PATENT

Rafael P. Mellado. Nueva quitinasa de origen bacteriano con amplio espectro fungicida. **PCT/ES2009/07035**. International. 2009. CSIC

Taxonomic breakdown of the more relevant phyla from the three soils seeded with maize NK603. Left: The percentages of Actinobacteria and different members of the Proteobacteria phyla are indicated. The total percentage of Proteobacteria from each soil is indicated in the right margin. Right: The herbicide treatment (lower panel) does not allow weed growth (upper panel).

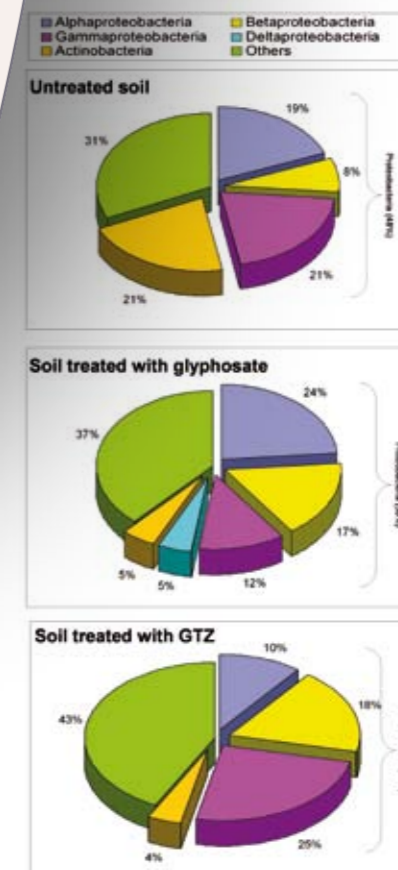



## Microbial Biotechnology

LEAD INVESTIGATOR

Miguel Vicente

POSTDOCTORAL SCIENTISTS

Ana Isabel Rico  
Paolo Natale  
Susanne Gola  
Alicia Sánchez



PREDOCTORAL SCIENTISTS

Manuel Pazos  
Marcin Krupka  
Cristina Ortiz

TECHNICIANS

Pilar Palacios  
Mercedes Casanova

PROJECT MANAGERS

Susana Pereira  
Moira Torrent

## Genetic Control of the Cell Cycle

This group works to find inhibitable targets in essential bacterial functions, namely cell growth and division, with the purpose of designing assays to identify new antimicrobials.

We first study the proliferation of a Gram-negative bacteria, *Escherichia coli*, of which there are both commensal and pathogenic strains. We extend our research to study specific topics related to the proliferation of two pathogens, *Streptococcus pneumoniae*, the causative agent of serious infections, and *Mycobacterium tuberculosis*, a widespread pathogen that affects one third of the world population. We summarise two studies published in the last two years.

In the assembly of the *E. coli* divisome, we found that FtsN is required for the correct assembly and stability of the *Escherichia coli* proto-ring. The proto-ring is formed by three essential proteins, FtsZ, FtsA and ZipA. This structure is the first that assembles at midcell to initiate the division ring that, once completed, integrates into the divisome and effects cell division. FtsN, considered the last division protein to be recruited into the divisome, is required for proto-ring stability in the living cell. In its absence, the already-formed rings of FtsQ, FtsA, ZipA and even FtsZ disassemble. The ZipA in the proto-ring is the most sensitive to the decrease in FtsN levels (Rico et al., 2010. *Mol Microbiol* 76:760-771).

In collaboration with P. Gómez-Puertas (CBMSO), we studied the need for potassium and neutral pH to attain the optimal GTPase activity and polymerisation of FtsZ, the prokaryotic orthologue of tubulin. We used molecular dynamics simulations of the *Methanococcus janaschii* FtsZ dimer in the presence of GTP-magnesium and monovalent cations. The presence of potassium at the GTP binding site allows the positioning of one water molecule, promoting dimer stability and GTP hydrolysis. Sodium destabilizes the dimer and does not allow positioning of the water. Simulation of low pH by protonation of the gamma phosphate of GTP indicated that both the monovalent cation and the water molecules are excluded from the binding site. The simulation therefore

predicted that at low pH, the FtsZ GTP-ase activity is lower and the dimer more stable. These predictions were tested experimentally and shown to be correct by analyzing the GTPase and polymerization activities of *M. janaschii* and *E. coli* FtsZ proteins in the test tube (Mendieta et al., 2009. *J Mol Biol* 390:17-25).

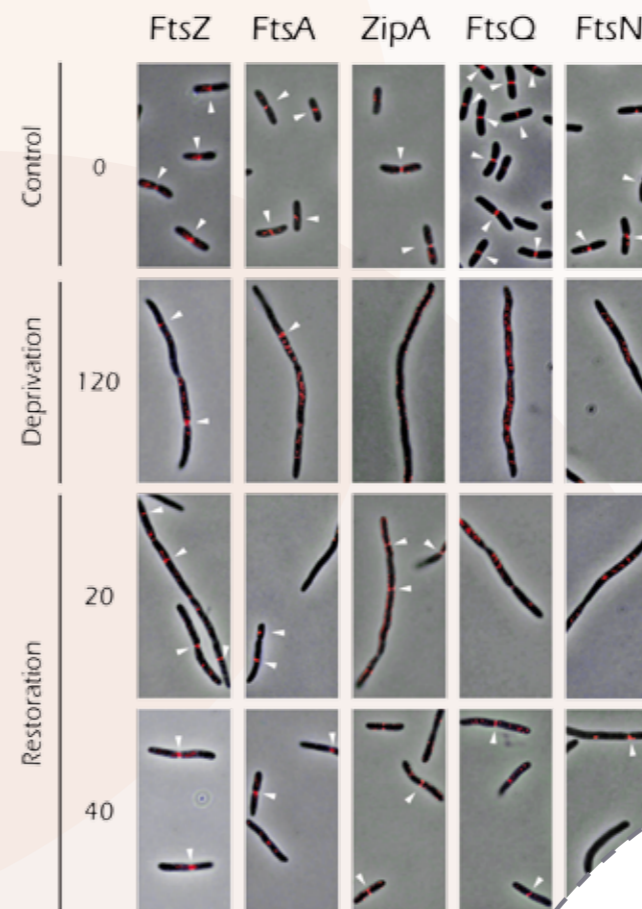

Kinetics of ring disappearance when bacteria are deprived of the FtsN protein. Each column shows the image for each kind of ring as indicated. The images in the two bottom rows show the restoration of FtsN in the cells. Proteins were developed by immunostaining with specific fluorescently-labelled antibodies (from Rico et al., 2010. *Mol Microbiol* 76:760-771).

### SELECTED PUBLICATIONS

Mendieta J, Rico AI, López-Viñas E, Vicente M, Mingorance J, Gómez-Puertas P (2009) Structural and functional model for ionic (K<sup>+</sup>/Na<sup>+</sup>) and pH dependence of GTPase activity and polymerization of FtsZ, the prokaryotic ortholog of tubulin. *J Mol Biol* 390:17-25.

Gola S, Manganelli R, García MJ, Vicente M (2009) News from the antituberculosis front at two recent European meetings. *World J Microbiol Biotechnol* 25:1129-1143.

Paez A, Mateos-Gil P, Hörger I, Mingorance J, Rivas G, Vicente M, Vélez M, Tarazona P (2009) Simple modeling of FtsZ polymers on flat and curved surfaces: correlation with experimental in vitro observations. *PMC Biophysics* 2:8.

Rico AI, García-Ovalle M, Palacios P, Casanova M, Vicente M (2010) Role of *Escherichia coli* FtsN protein in the assembly and stability of the cell division ring. *Mol Microbiol* 76:760-771.

Mingorance J, Rivas G, Vélez M, Gómez-Puertas P, Vicente M (2010) Strong FtsZ is with the force: mechanisms to constrict bacteria. *Trends Microbiol* 18:348-356.

Molecular Dynamics modelling of FtsZ GTPase activity. Scheme of the position of selected atoms surrounding GTP in the FtsZ dimer interface after 5 ns simulation in presence of potassium. A water molecule is located within the coordination sphere of potassium (purple) in a position compatible for hydrolysis of the GTP molecule (Mingorance et al., 2010. *Trends Microbiol* 18:348-356).

